

MAS[®]

Mark Anderson Sales

Wall Hung Wash Trough

Installation Guide

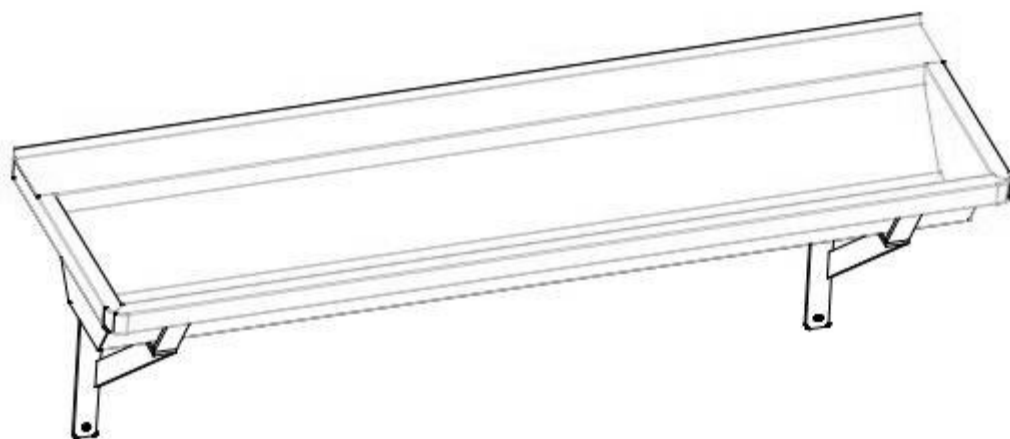

MAS[®] **20**
CELEBRATING YEARS

Brisbane H.O
4/84 Ingleston Road
Wakerley QLD 4154
07 3890 8011
sales@masales.com.au
masales.com.au

Important

All installations and services must be carried out by a licenced plumber in accordance with the plumbing code of Australia AS/NZS 3500.2
And installed to the appropriate standards in conjunction with local state or territory requirements

All MAS wash troughs are manufactured to exceed industry standards and performance made from 1.2mm thick 304 grade stainless steel under strict controlled conditions

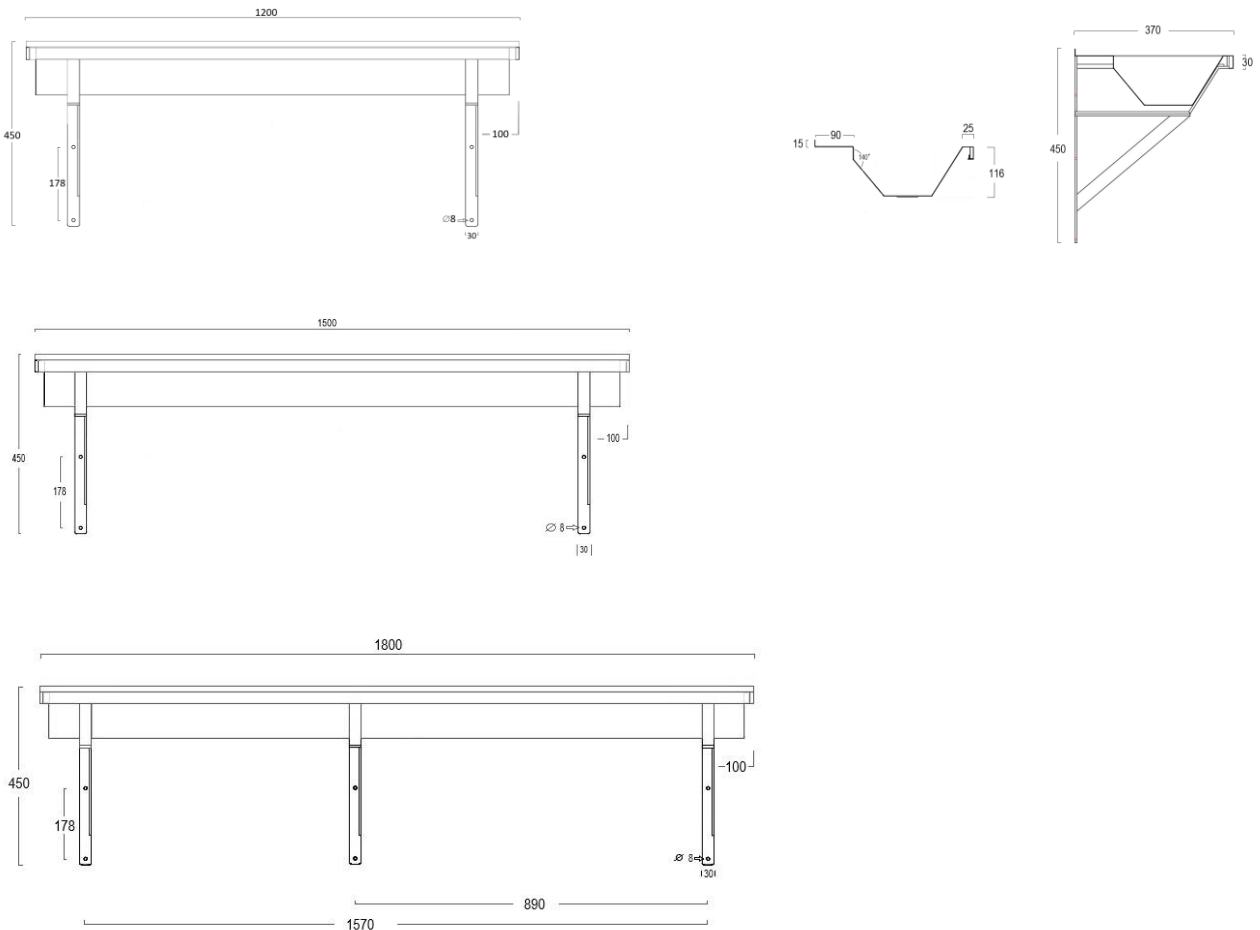

Any discrepancies or damages in supply must be reported to MAS within seven (7) days of invoice by phone or email
No claims will be considered unless reported within specified time
Phone : 07 3890 8011 Email : sales@masales.com.au



Installation



- Before installation ensure the substructure has been prepared to accommodate all necessary services for supply and discharge. Please refer to attached diagram for the MAS wash trough model requirements. Ensure the substrate is clean and plumb, all walling must be perfectly flat and square for installation.
- Complete assembly of the wall brackets prior to installation by fixing the lower part of the bracket to the fixed upper with the screws provided. Tools required 6mm Allen Key 13mm spanner or socket
The lower bracket is universal left or right hand side.
- Please note the brackets are constructed from 5mm stainless steel bar that is welded and then nano coated for longevity, some discolouration is expected.



Installation

- Complete the rough in of all necessary services for inlet and outlet, ensuring there is adequate space for services. Ensure the walling is adequate to support the weight of the specific model, in severe failure of the outlet a significant water weight will be held in the trough, be sure to allow for this. Ensure the fixings screws of the wash trough will meet up with studs, if not fit noggins as needed. Please see individual drawings for fixing hole positions.
- Ensure the wash trough sits flush against the wall surface and then install fixing anchors. All fixing points on all brackets must be securely anchored with “fit for purpose” screws or dyna bolts. Add screws to the splashback as necessary by pre drilling use only minimum 304 grade stainless screws.
- Fit the 50mm Plug & waste provided to the outlet ensuring to seal and tighten. Complete all connections for the waste.
- Clean the wash trough as needed for handover, following the cleaning instructions provided.



Caring for your Stainless Steel product

Your MAS Wash Trough is made from quality type 304 stainless steel. With proper care and maintenance your urinal will give you many years of service.

Following these simple tips and cleaning routines will ensure the long life of your MAS stainless steel trough.

Weekly Care

Preventative maintenance is important to maintain the finish of your stainless steel. To thoroughly clean your stainless, use a non-abrasive stainless steel cleaner (available from your local supermarket or hardware) and follow the directions on the product being sure to cover the entire surface completely, rinse thoroughly and dry with a soft cloth.

Stains and Rust

By its very nature stainless steel is resistant to rust. A build up of iron particles from external sources, heavy use or water supply commonly causes rust on the surface of the stainless steel. The quality of your water supply can also often cause stains to appear on your stainless. Both rust spots and staining can be removed with a thorough clean (see Weekly cleaning).

Scratches

Scratches are inevitable with all stainless steel products. With regular use the scratches will blend together and form a uniform finish. The appearance of these scratches can be reduced by the use of a fine 3M Scotch Brite pad; wipe along the grain of the entire area and rinse thoroughly (rubbing across the grain will dull the finish and introduce more scratches).

What to avoid

Avoid Chlorides are very aggressive to stainless steel. These are commonly found in detergents, soaps, bleaches and drain cleaners. Thoroughly rinse your sink after using one of these products to avoid surface pitting.

Avoid steel wool to clean your stainless steel. It will leave behind steel fragments that will cause rust spots.



Warranty Conditions

For full warranty please visit masales.com.au

MAS® is a registered trademark of Mark Anderson Sales Pty Ltd

The information contained on this sheet is to be read in conjunction with any other warranty, installation or care information provided to you by Mark Anderson Sales located at Building 4 84 Ingleston Road Wakerley QLD 4154.

Our goods are supplied with guarantees that cannot be excluded under Australian Consumer Law.

Conditions

All stainless-steel products manufactured by MAS for commercial applications are covered by a 12-month manufacturer's warranty from date of installation or 24-months from date of invoice whichever occurs first. If a product is on-sold by another party other than MAS the seller has no authority to offer additional warranties on behalf of MAS or any other MAS products.

All supplied products must be installed by a qualified and licensed contractor in accordance with the plumbing code of Australia and installed to the appropriate standards in conjunction with local state or territory requirements.

Components such as valves, pressure limiting valves, temperature mixing valves and flexible hoses supplied with an MAS assembled product are covered by the suppliers (manufacturer) warranty. Any extension of warranty terms offered by third parties will be the responsibility of those companies

Claims made under warranty conditions must be made within a reasonable period of the discovery of a defect.

Visual imperfections or defects that are ignored at the time of install will be excluded from all warranty conditions and all warranty responsibilities will be forfeited.

MAS will repair or replace at our discretion any product part which is proven to be defective through faulty materials or workmanship within the warranty period. Repair or replacement of a product under the terms of this warranty does not give rise to an extension of original warranty period.

Where a product is installed outside the boundaries of a metropolitan area, the cost of any transport or travelling shall be the responsibility of the claimant.

Liability outside of statutory requirements is limited to the purchase price paid for the product or to the repair or replacement of the product. Any other loss directly or indirectly due to malfunction of the product is excluded from the warranty.

Standard Exclusions

- Normal wear and tear
- Accidental or malicious damage
- Third party product causing failure
- Incorrect or not fit for purpose installation
- Any unauthorized alteration, modification or substitution
- Failure due to excessive or insufficient water supply
- Failure from foreign matter from installation or water supply
- Any and all consequential loss or damage, directly or indirectly caused by malfunction
- Acts of God



masales.com.au

Wash Trough installation guide MS Rev 1 2024